

# Demolition and Sorting Grab with cylinder 8-12t / 17,600-26,400lbs D12H-P

Robust multi purpose grabs for excavators from 8t / 17,600lbs to 12t / 26,400lbs operating weight. Well-suited for demolition and separation of all kinds of building materials and waste.

- ▷ Including flat 15t rotator – **low height!** Integrated **non-return valve** to avoid peak-pressures.
- ▷ **High closing force** (36kN/7,920lbf) thanks to two horizontal cylinders, completely protected by the shell carrier.
- ▷ The **end position** (grab open) is **hydraulically cushioned** to avoid damage to the cylinder when the grab is pushed into the material.
- ▷ The grab features a **perforated skin** to let fine dust and debris through without larger pieces getting caught. The durable, replaceable and **indexable wear blades** (500HB) enable the grabs to pinch with their edges without excessive wear.



Request? exc@kinshofer.com

## Demolition and Sorting Grab D12H-P

Type	Width E (mm/in)	Opening A (mm/in)	Height C max. (mm/in)	Height C min. (mm/in)	Volume (liter/c.y.)	Weight (kg/lbs)	Load capacity (kg/lbs)
D12H-P-60	600 / 23.6	1,550 / 61	1,125 / 44.2	980 / 38.5	225 / 0.29	470 / 1,034	3,000 / 6,600

**Package consists of:** demolition and sorting grab, **KINSHOFER** rotator, non-return valve, wear plates

## KINSHOFER Rotator

Continuous rotation and two oil passages. Overload protection is ensured by pressure relief valves.

Type	Upper dimension (hole/Ø-hole pattern) (mm/in)	Torque (Nm/ft.lbs)	Bending moment max. (Nm/ft.lbs)
KM 15 F273/273	10 x M16; Ø 273 / 10.7	2,000 / 1,475	50,000 / 36,875

## Accessories

Type	Description
KM 690 15t	adapter for rigid mounting – up to 15t/33,000lbs
OQ45/4 rigid	bolt-on adapter for Oilquick OQ45 – 5t/11,000lbs to 12t/26,400lbs
KSW08 rigid	bolt-on adapter for system L-Lock KMS08L/KHS08L for rigid mounting – up to 12t/26,400lbs
	adapters for quick change systems from other manufacturers or different sizes on request
KM 980-2 2t-8t c	solenoid valve for additional circuit, up to 26MPa/3,770psi, incl. parts and mounting

## Requirements of carrier machine

Operating pressure (open/close):	max. 32 MPa (320 bar) / 4,640 psi
Recommended pump capacity (open/close):	75 - max. 150 l/min / 20 - max. 40 GPM
Hydraulic connection (open/close):	G 3/4" / G 1/2"
Operating pressure (rotate):	max. 20 MPa (200 bar) / max. 2,900psi
Recommended pump capacity (rotate):	max. 60 l/min / max. 16 GPM

## Technical drawing

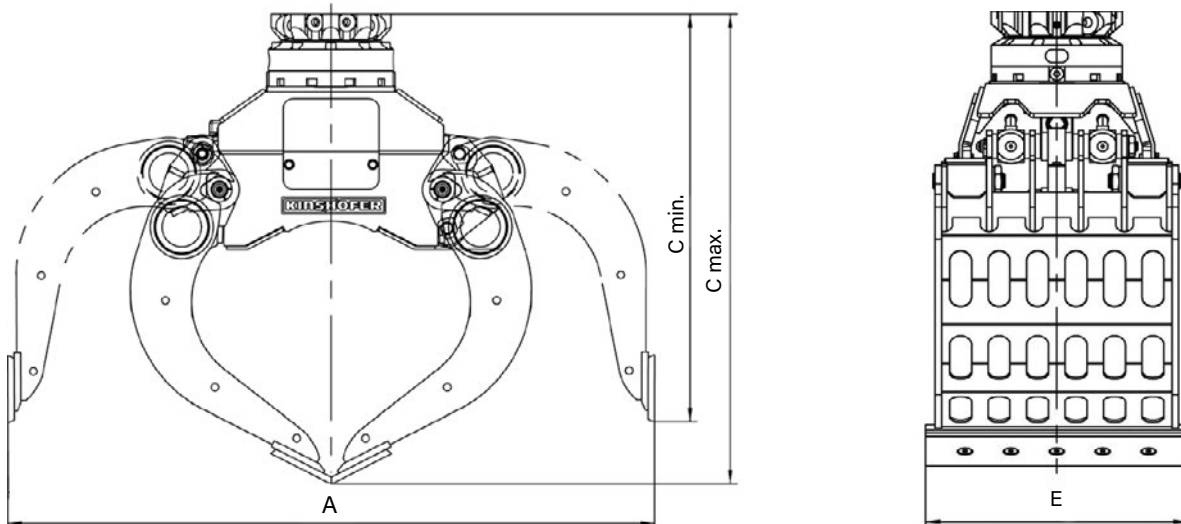

# Demolition and Sorting Grabs 10-37t / 22,000-81,400lbs D15H-P to D37H-P

**Robust Demolition and Sorting Grabs for excavators from 10t / 22,000lbs to 37t / 81,400lbs operating weight. Well-suited for demolition and separation of all kinds of building materials and waste.**

- ▷ **Robust, fully integrated rotation** with sturdy slewing ring to withstand external forces, with connecting hoses located inside the hub. Hydraulic quick change adapters are directly mountable to the head plate. Different bolt patterns are available. **Integrated pressure relief valve** to avoid peak-pressures in rotation motor(s).
- ▷ **Exceptional closing forces** provided by two horizontal hydraulic cylinders which are well protected by the carrier.
- ▷ The **end position (grab open)** is **hydraulically cushioned** to avoid damage to the cylinder when the grab is pushed into the material.
- ▷ The grabs feature **perforated shells** to let fine dust and debris through without larger pieces getting caught. The **durable, replaceable and indexable wear blades** (500HB) enable the grabs to pinch with their edges without excessive



D24H-P

## Demolition and Sorting Grabs D15H-P / D20H-P / D24H-P / D27H-P / D37H-P

Type	Width E (mm/in)	Opening A (mm/in)	Height C max. - min. (mm/in)	Volume (liter/c.y.)	Weight (kg/lbs)	Load capacity (kg/lbs)	Closing force (kN/lbf)	Operating weight (t/lbs)
D15H-P-80	800 / 31.5	1,550 / 61.0	1,215 - 1,070 / 47.8 - 42.1	300 / 0.39	630 / 1,386	4,000 / 8,800	27 / 5,940	10 - 15 / 22,000 - 33,000
D20H-P-100	1,000 / 39.4	1,890 / 74.4	1,400 - 1,205 / 55.1 - 47.4	450 / 0.59	1,120 / 2,464	5,000 / 11,000	43 / 9,460	14 - 20 / 30,800 - 44,000
D24H-P-100	1,000 / 39.4	2,005 / 78.9	1,470 - 1,235 / 57.9 - 48.6	650 / 0.85	1,175 / 2,585	5,000 / 11,000	42 / 9,240	18 - 24 / 39,600 - 52,800
D27H-P-115	1,150 / 45.3	2,145 / 84.4	1,575 - 1,375 / 62.0 - 54.1	800 / 1.05	1,600 / 3,520	6,000 / 13,200	63 / 13,860	20 - 27 / 44,000 - 59,400
D32H-P-120	1,200 / 47.2	2,200 / 86.6	1,590 - 1,460 / 62.6 - 57.5	900 / 1.18	2,050 / 4,510	8,000 / 17,600	89 / 19,580	27 - 32 / 59,400 - 70,400
D37H-P-125	1,250 / 49.2	2,260 / 89.0	1,620 - 1,480 / 63.8 - 58.3	950 / 1.24	2,100 / 4,620	8,000 / 17,600	86 / 18,920	32 - 37 / 70,400 - 81,400

**Package consists of:** demolition and sorting grab, integrated rotation with sturdy slewing ring, wear blades and non-return valve

## Accessories

Type	Description
KM 690 15t	adapter for rigid mounting - up to 15t/33,000lbs
KM 690 20t	adapter for rigid mounting - up to 20t/44,000lbs
KM 690 27t	adapter for rigid mounting - up to 27t/59,400lbs
KM 690 32t	adapter for rigid mounting - up to 32t/70,400lbs
OQ	bolt-on-adapter for Oilquick - up to 70t/154,000lbs available
KSW10 rigid	bolt-on-adapter for system L-Lock KMS10L/KHS10L - up to 19t/41,800lbs.
KSW21/25 rigid	bolt-on-adapter for system L-Lock KMS21/25L / KHS21/25L - up to 40t/88,000lbs adapters for quick change systems from other manufacturers or different sizes available on request

## Requirements of carrier machine

<b>Operating pressure (open/close):</b>	D15 - D20: max. 32 MPa (320 bar) / 4,640 psi; D24 - D37: max. 35 MPa (350 bar) / 5,070 psi
<b>Pump capacity (open/close):</b>	D15 - D37: 75 - max. 150 l/min / 20 - max. 40 GPM
<b>Hydraulic connections (rotate):</b>	D15 - D20: G 3/4" / G 1/2"; D24 - D37: G 1" / G 1/2"
<b>Operating pressure (rotate):</b>	D15 - D37: max. 14 MPa (140 bar) / 2,030 psi
<b>Pump capacity (rotate):</b>	D15 - D37: max. 50 l/min / 13 GPM

## Technical drawings

